



ST. HILDA'S PRIMARY SCHOOL
END-OF-YEAR EXAMINATION, 2025

PRIMARY 5

SCIENCE

Booklet A

Name : _____ (37)

Class: Primary 5 / _____

Date: 22 October 2025

Total Time for Booklets A and B: 1 hour 45 minutes

Additional Materials: Optical Answer Sheet (OAS)

INSTRUCTIONS TO CANDIDATES

1. Write your name, index number and class above.
2. Do not turn over this page until you are told to do so.
3. Follow all instructions carefully.
4. Answer all questions.
5. Use a 2B pencil to shade your answers on the Optical Answer Sheet (OAS).

This booklet consists of 21 printed pages.

For each question from 1 to 30, four options are given. One of them is the correct answer. Make your choice (1, 2, 3 or 4) and shade your answer on the Optical Answer Sheet.

(60 marks)

- 1 Muthu conducted an experiment with a pot of plant which was placed in a thick cardboard box with a hole. He shone a torch at the hole for a week. The diagram below shows the plant at the start of the experiment and after a week.

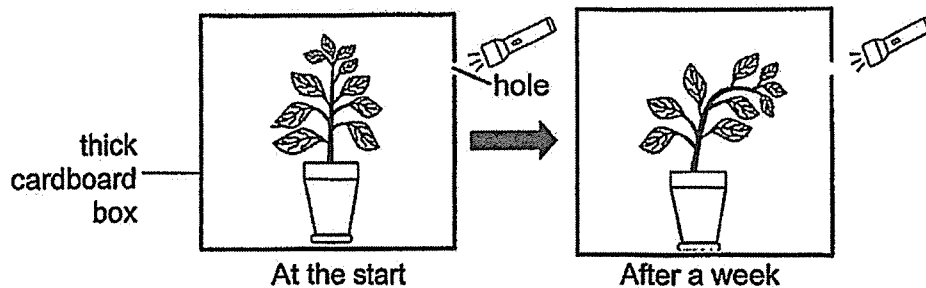

Which characteristic of living things is shown by the above experiment?

- (1) Living things reproduce.
 - (2) Living things need air to survive.
 - (3) Living things respond to changes.
 - (4) Living things need water to survive.
- 2 The diagram shows the human circulatory system. P, Q, R and S are the blood vessels.

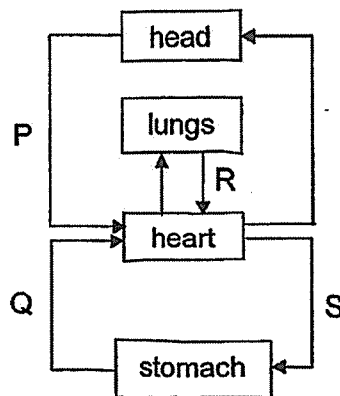

Which statement is correct?

- (1) Blood in P has more oxygen than blood in S.
- (2) Blood in P has more oxygen than blood in R.
- (3) Blood in Q has less carbon dioxide than blood in S.
- (4) Blood in Q has more carbon dioxide than blood in R.

3 Which row shows the correct path taken by the food after it enters the mouth?

(1)	mouth → windpipe → stomach → small intestine → large intestine → anus
(2)	mouth → windpipe → stomach → blood vessels → large intestine → anus
(3)	mouth → gullet → stomach → large intestine → small intestine → anus
(4)	mouth → gullet → stomach → small intestine → large intestine → anus

4 The diagram shows the human respiratory system.

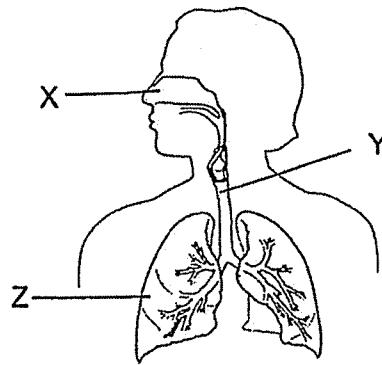

Which statement(s) is/ are correct?

- A X traps dust from the inhaled air.
- B Y allows the exchange of gases.
- C Carbon dioxide from blood enters the respiratory system at Z.

- (1) A only
- (2) A and B only
- (3) A and C only
- (4) A, B and C

- 5 Mr Tan did some activities over a period of time. The graph shows the changes in his heart rate.

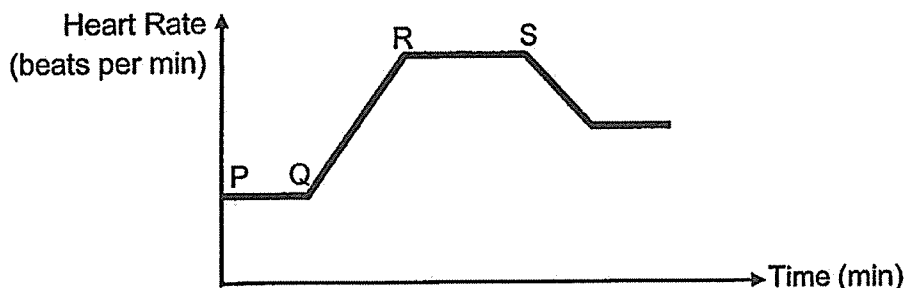

Based on the graph above, which row correctly shows Mr Tan's actions at points Q or R?

	Points in graph	Actions
(1)	Q	Stopped running
(2)	Q	Started running
(3)	R	Started resting
(4)	R	Started walking

- 6 The diagram shows the transport systems of the human and fish.

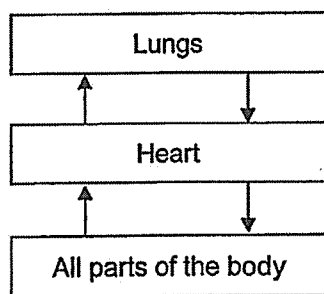

Human

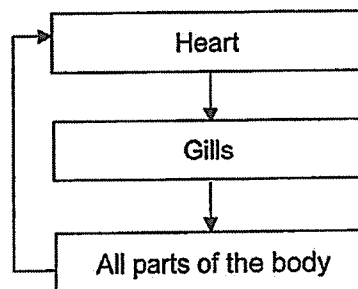

Fish

Which of the following statements is **not** true?

- (1) Blood passes through the heart twice for a human being but passes through the heart once for the fish.
- (2) Blood rich in oxygen passes from all parts of the body to the heart for both the human and the fish.
- (3) Blood rich in carbon dioxide passes from all parts of the body to the heart for both the human and the fish.
- (4) Blood rich in oxygen for the human flows from the heart to all parts of the body but blood poor in oxygen for the fish flows from the heart to the gills.

The diagram below shows the life cycles of a beetle and cockroach.

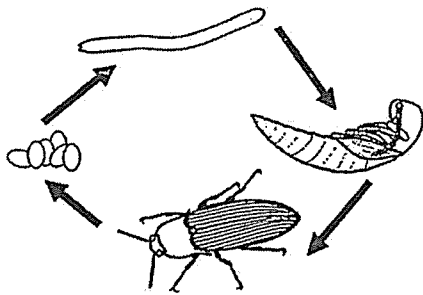

Life cycle of a beetle

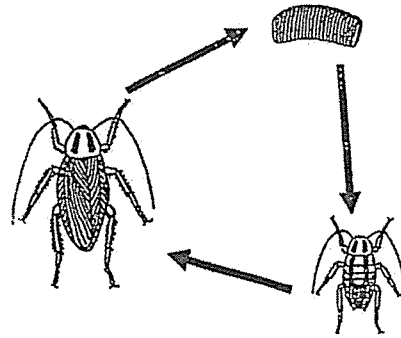

Life cycle of a cockroach

Which statement(s) correctly describe(s) the life cycles of the beetle and cockroach?

- A Both the beetle and the cockroach lay eggs.
- B Both the youngs of the beetle and the cockroach look like the adults.
- C The beetle does not eat at the pupal stage but the cockroach eats at the nymph stage.

- (1) A only
- (2) A and C only
- (3) B and C only
- (4) A, B and C

8 The diagram shows the tiny openings found on the leaves of plants.

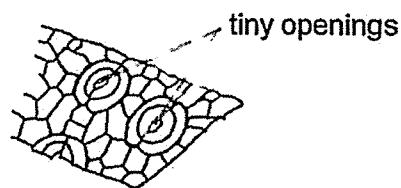

Which of the following is **not** a function of the tiny openings?

- (1) Trap light to make food for the plant.
- (2) Oxygen enters through the tiny openings.
- (3) Water vapour exits through the tiny openings.
- (4) Carbon dioxide exits through the tiny openings.

9 The diagram shows a family tree.

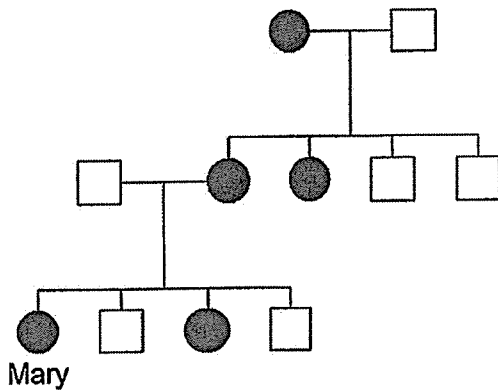

Key

- Female with disease X
- Male with disease X
- Female without disease X
- Male without disease X

Which statement(s) is / are true?

- A Mary has two brothers and one sister.
- B Mary inherited disease X from her aunt.
- C Disease X is passed through the female members of the family only.

- (1) A only
- (2) B only
- (3) A and C only
- (4) A, B and C

10 The diagram below shows the life cycle of a flowering plant.

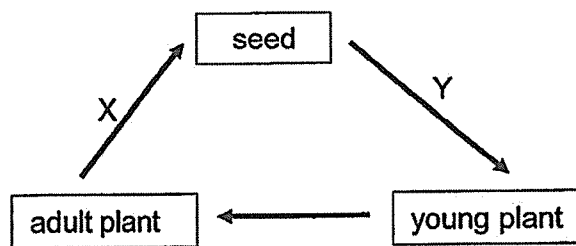

Which row shows the processes taking place at X and Y?

	X	Y
(1)	Fertilisation	Pollination
(2)	Pollination	Fertilisation
(3)	Germination and Fertilisation	Pollination
(4)	Pollination and Fertilisation	Germination

Use the information below to answer Questions 11 and 12.

Three flowers, A, B and C, from the same plant had some parts removed from each of them.

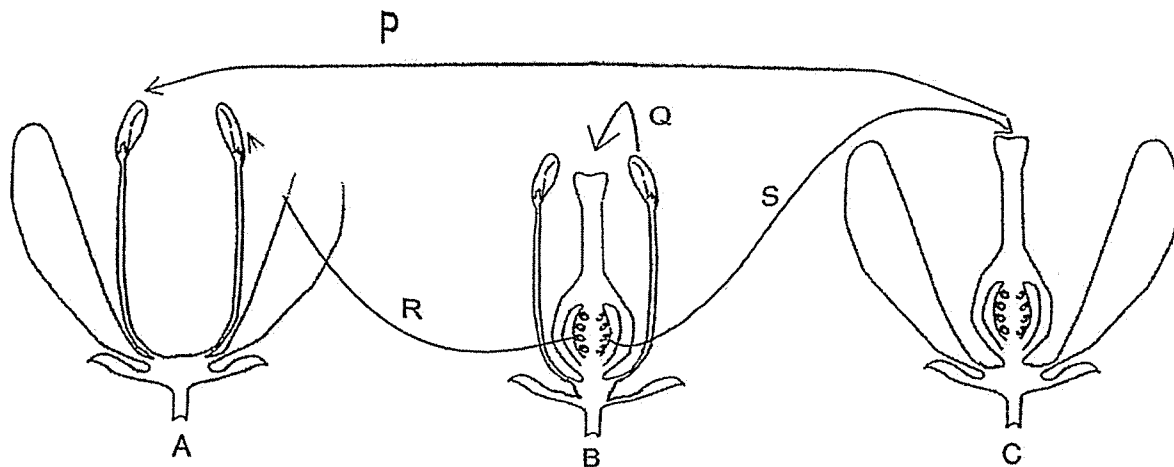

11 Which arrow(s) show(s) the process of pollination?

- (1) Q only
- (2) P and Q only
- (3) S and R only
- (4) P, R and S only

12 One of the above flowers, A, B or C, will not be able to develop into a fruit. Which row shows the correct explanation?

	Flower that will not develop into a fruit	Explanation
(1)	A	Flower A has no ovary for fertilisation to occur.
(2)	B	Flower B has no petal to attract pollinators.
(3)	C	Flower C has no anther for pollination to occur.
(4)	C	Flower C has no anther to produce pollen grains.

- 13 Siva wanted to investigate if seeds need warmth to germinate. He placed three bean seeds and some cotton wool into each of the four similar cups, E, F, G and H. The cups were then placed in the respective locations with conditions as shown below.

Cups	Cotton Wool	Temperature of surroundings (°C)	Location
E	Wet	0	In a black box
F	Wet	0	In a transparent box
G	Wet	28	In a black box
H	Dry	28	In a transparent box

Which two cups should he use for his investigation?

- (1) E and F
 - (2) E and G
 - (3) F and H
 - (4) G and H
- 14 The diagram shows the female and male reproductive systems.

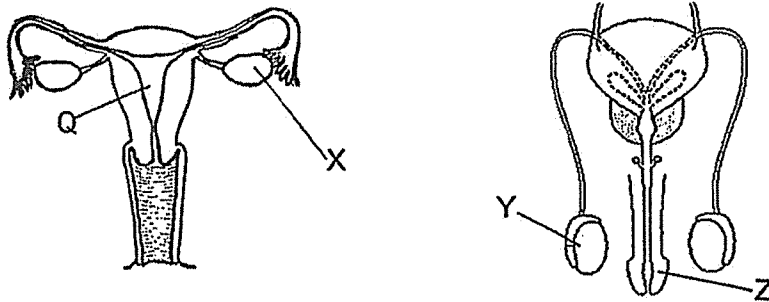

Which of the following shows the parts that produce the human reproductive cells?

	Part that produces the	
	Female reproductive cell	Male reproductive cell
(1)	Q	Y
(2)	X	Z
(3)	X	Y
(4)	Q	Z

15 Study the diagram of a plant.

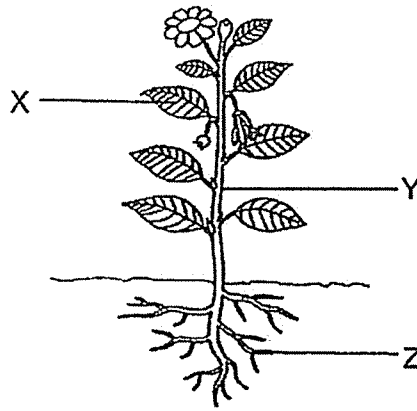

Which statement(s) correctly describe(s) the function of parts X, Y and Z?

- A X takes in water for the plant.
- B Y holds the plant upright to get more sunlight.
- C Z takes in food from the ground.

- (1) B only
- (2) A and B only
- (3) B and C only
- (4) A, B and C

- 16 A celery stalk which had a part of its stalk removed was placed in a beaker of blue-coloured water as shown in the diagram below. After two days, the stalk was cut across the dotted line at AB as shown in the diagram.

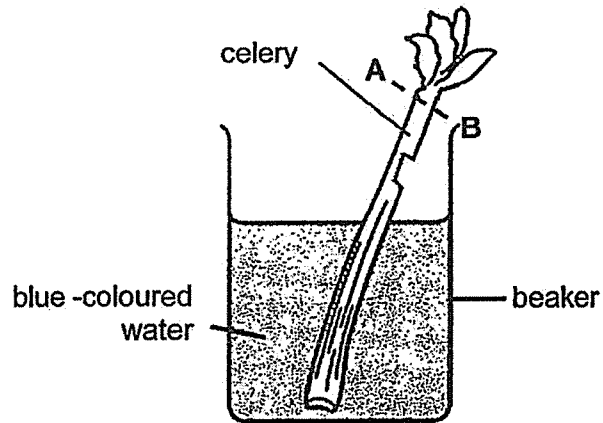

Which diagram shows the cross section of the celery stalk at AB?

(1)

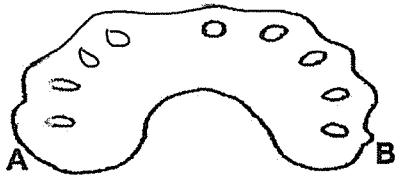

(2)

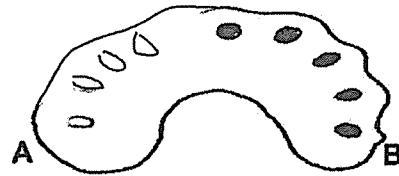

(3)

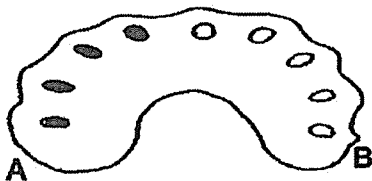

(4)

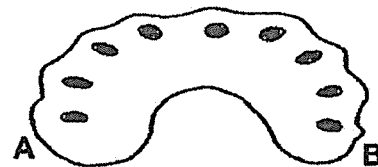

- 17 Xiao Ming sets up an experiment as shown below. He placed the three set-ups at the school field for three days. He measured the volume of water left in each set-up at the end of each day.

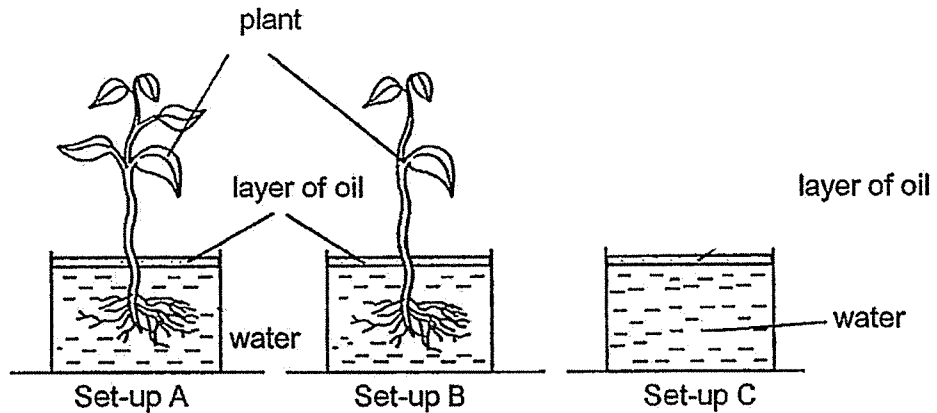

Xiao Ming was trying to find out if _____.

- (1) the plant takes in water
 - (2) water from the beakers will evaporate
 - (3) roots of the plant are needed to take in water
 - (4) the number of leaves affect the volume of water taken in by the plant
- 18 The diagram shows a badminton net.

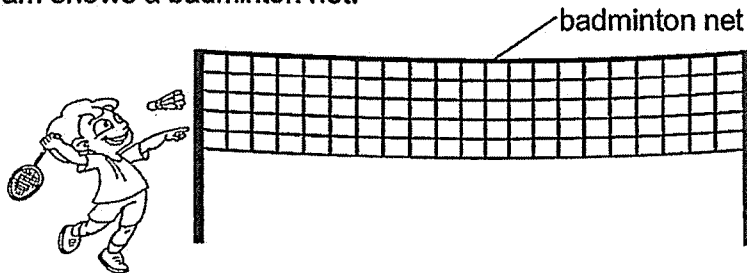

Based on the properties shown, which material is most suitable for making the badminton net?

	Material	Property		
		strong	flexible	reflects light into eyes
(1)	P	✓	✓	✓
(2)	Q	✗	✓	✓
(3)	R	✓	✗	✗
(4)	S	✓	✗	✓

Key
 ✓ : yes
 ✗ : no

- 19 Terry placed a balloon inside a plastic bottle filled with air as shown. An air pump is used to inflate the balloon. After three pumps, the balloon can no longer increase in size.

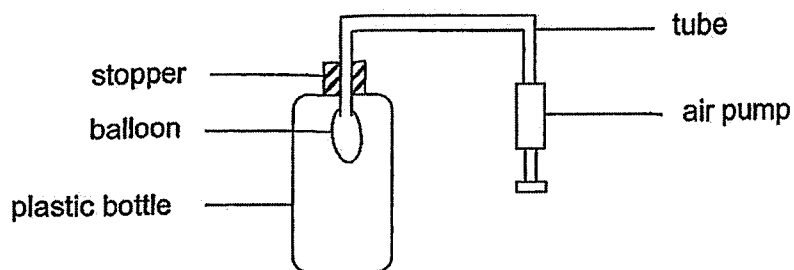

What can Terry do to inflate the balloon further?

- A use a longer tube
- B remove the stopper
- C use a smaller air pump
- D make some holes in the plastic bottle

- (1) A and B only
- (2) B and D only
- (3) B and C only
- (4) C and D only

20 Krishnan shone light onto object S from three different directions and obtained the following shadows.

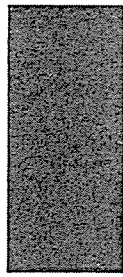

direction 1

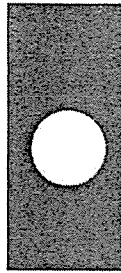

direction 2

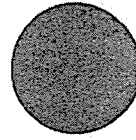

direction 3

Which of the following could be the shape of object S?

(1)

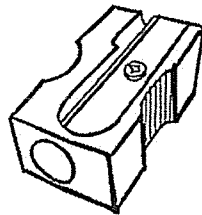

(2)

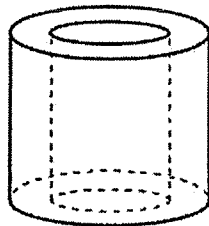
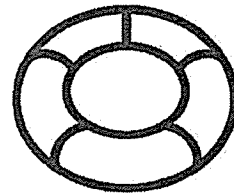

(4)

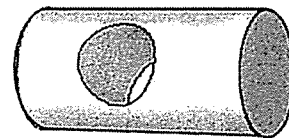

- 21 Ravi set up an experiment by first heating two blocks, D and E, of the same size but different materials to a temperature of 60 °C. After that, both blocks were then placed on the tabletop and their temperatures were taken every five minutes.

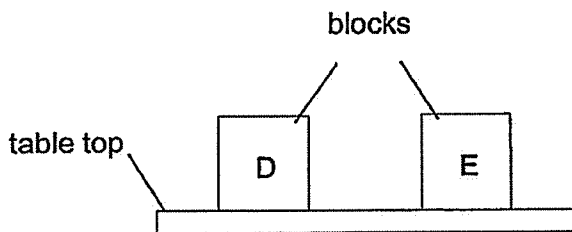

Time (min)	Temperature of block D (°C)	Temperature of block E (°C)
0	60	60
5	45	55
10	35	52
15	30	50

Which row correctly matches how the materials of blocks D and E can be used?

	Material of block D	Material of block E
(1)	To keep hot food warm	To cook food faster in a pot
(2)	To cook food faster in a pot	To keep hot food warm
(3)	To keep cold drinks cold	To cook food faster in a pot
(4)	To keep hot food warm	To keep cold drinks cold

- 22 The diagram shows how the magnets were arranged inside the two types of toy cars, J and M.

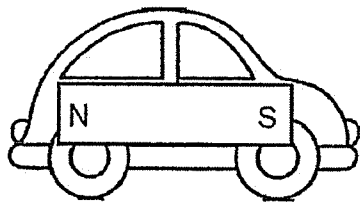

Arrangement of magnet
in toy car J

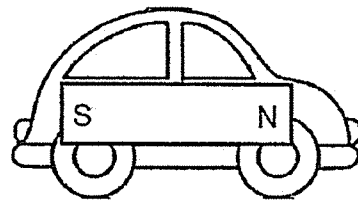

Arrangement of magnet
in toy car M

When toy car M is pushed, the rest of the toy cars would move and then stop in the following positions as shown.

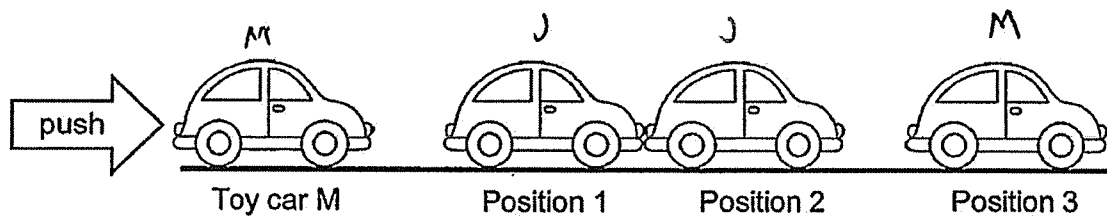

Which row shows the correct type of toy car, J or M at position 1, 2 and 3?

Type of toy cars at			
	Position 1	Position 2	Position 3
(1)	J	J	M
(2)	J	M	J
(3)	M	M	J
(4)	M	J	M

23 The diagram shows changes in the state of water.

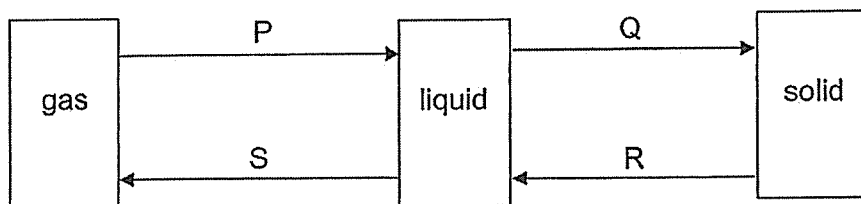

Which arrows represent melting and condensation?

	melting	condensation
(1)	P	Q
(2)	Q	P
(3)	R	P
(4)	S	R

24 Joe used the set-up below to represent the water cycle. He left the set-up under the sun and observed that some water was collected in the mug after 30 minutes.

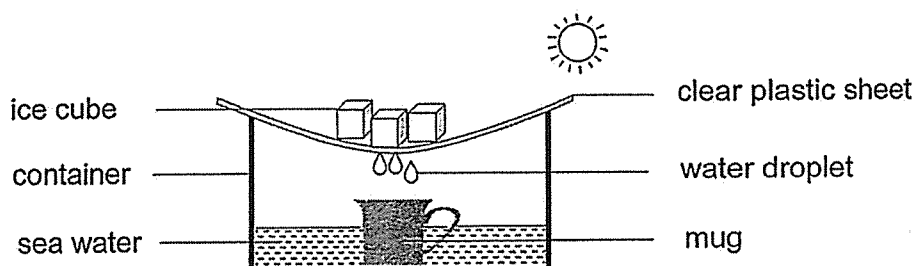

If Joe were to repeat the experiment, what could he do to collect more water after 30 minutes?

- A Put a heat source under the sea water
- B Remove ice cubes from the plastic sheet
- C Add more ice cubes onto the clear plastic sheet

- (1) B only
- (2) C only
- (3) A and B only
- (4) A and C only

25 The table shows the boiling and freezing points of three substances, P, Q and R.

Substances	Freezing point (°C)	Boiling point (°C)
P	0	25
Q	29	185
R	12	70

Which row shows the states of the substances P, Q and R at 27 °C?

	P	Q	R
(1)	liquid	solid	gas
(2)	gas	liquid	solid
(3)	gas	solid	liquid
(4)	solid	gas	liquid

26 Kathy left four different containers, S, T, U and V, at the same location. At the start of the experiment, each container contained 100 cm³ of water of the same temperature. At the end of each hour, she measured and recorded the volume of water left in each container. The graph below shows how the volume of water in each container changed over five hours.

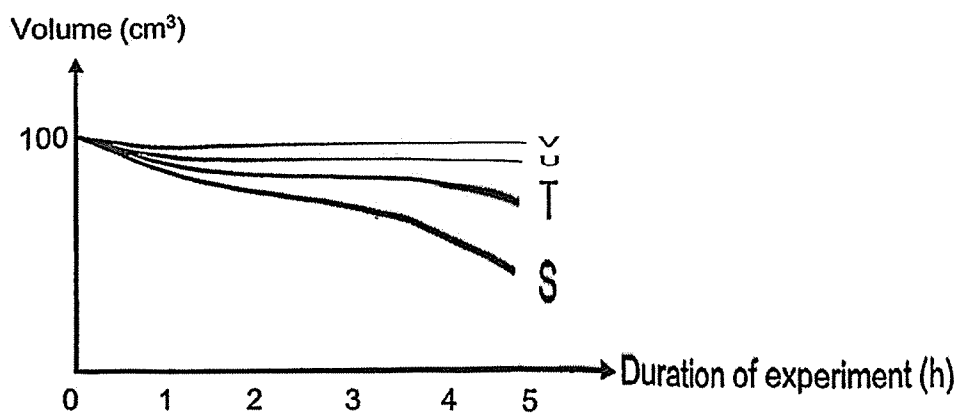

Based on the graph above, which statement is correct?

- (1) Water in U has a larger exposed surface area than water in T.
- (2) Water in V has a larger exposed surface area than water in S.
- (3) Water in T has a smaller exposed surface area than water in V.
- (4) Water in U has a smaller exposed surface area than water in S.

27 Damien connected a circuit tester to a circuit board as shown in the diagram below. He observed that the bulb light up.

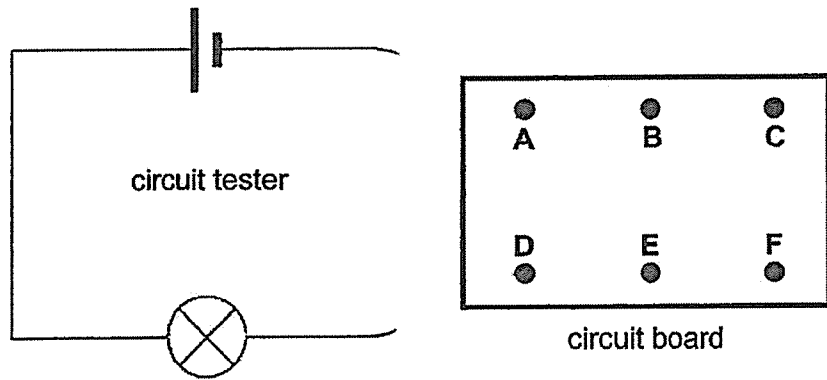

If the battery and bulb were in working condition, which of the following is / are possible circuit board(s) that he had used for his experiment?

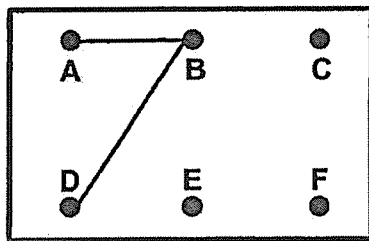

circuit board P

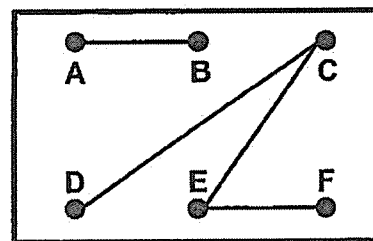

circuit board Q

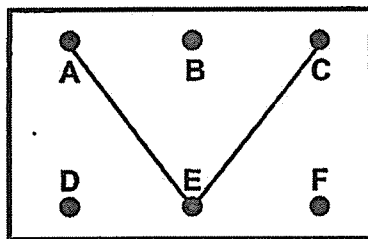

circuit board R

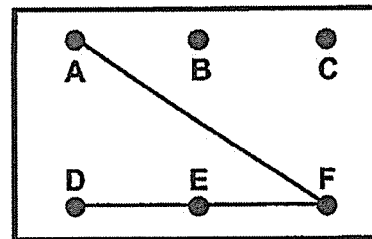

circuit board S

- (1) P only
- (2) Q and R only
- (3) P and S only
- (4) P, Q and S only

28 Four circuits were set up using identical batteries and bulbs in working condition.

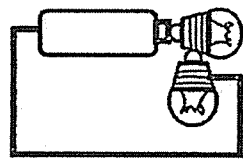

circuit W

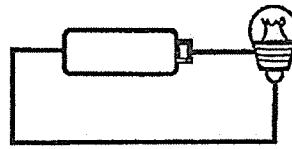

circuit X

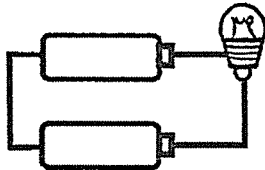

circuit Y

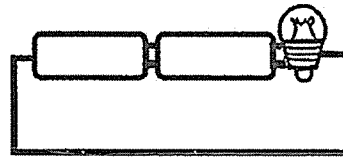

circuit Z

In which circuits would the bulbs light up?

- (1) W and X only
- (2) X and Y only
- (3) W, X and Y only
- (4) W, X, Y and Z

29 Darren sets up four electrical circuits as shown below.

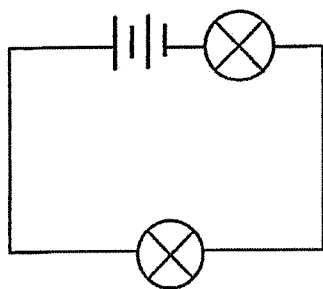

set-up P

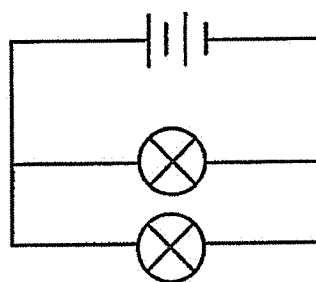

set-up Q

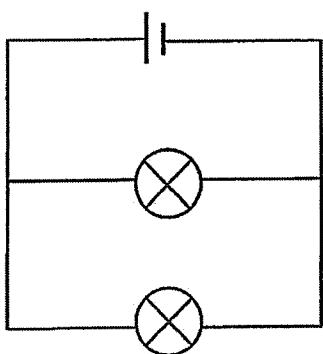

set-up R

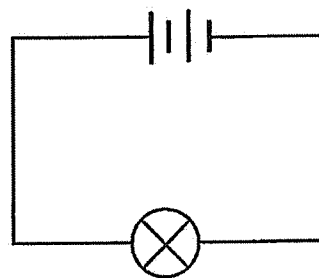

set-up S

He wants to investigate how the arrangement of bulbs in a circuit affects the brightness of each bulb.

Which two set-ups should he use for his investigation?

- (1) P and R
- (2) P and Q
- (3) Q and S
- (4) R and S

30 The diagram shows a hair dryer.

When only switch 1 is closed, the motor of the fan is turned on to blow out wind.

When both switches 1 and 2 are closed, the heater is turned on so that the wind that comes out from the hair dryer is hot.

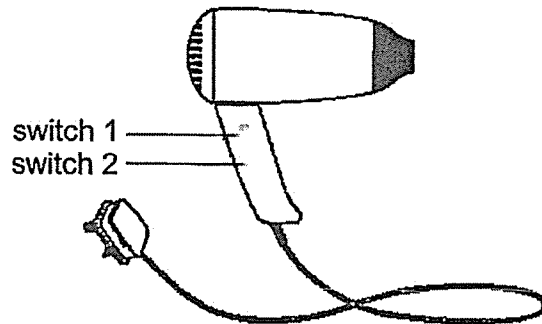

Which circuit diagram shows how the components of the hair dryer are connected?

(1)

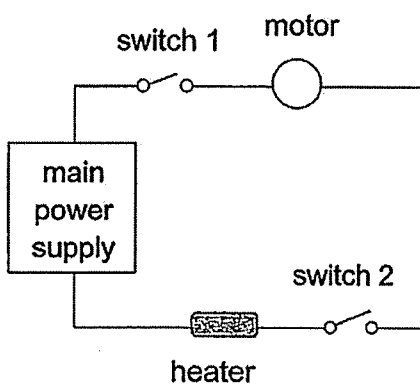

(2)

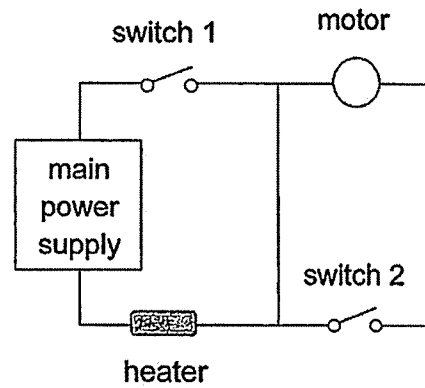

(3)

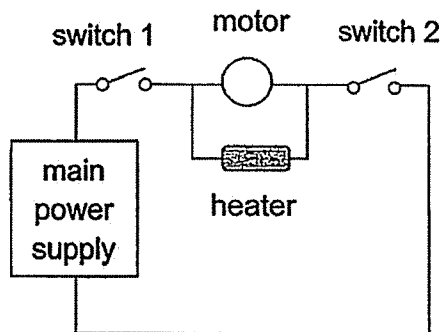

(4)

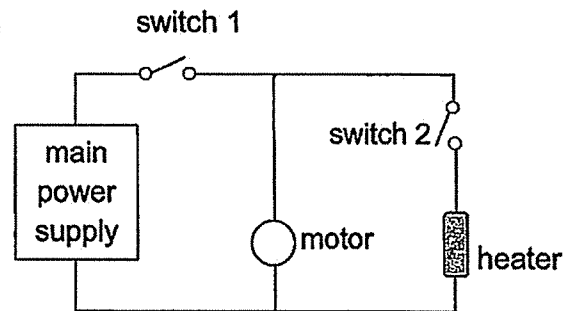

End of Booklet A

(Go on to Booklet B)



**ST. HILDA'S PRIMARY SCHOOL
END-OF-YEAR EXAMINATION, 2025**

**PRIMARY 5
SCIENCE**

Booklet B

Name : _____ ()

Class: Primary 5 / _____

Date: 22 October 2025

Total Time for Booklets A and B: 1 hour 45 minutes

Parent's Signature:

INSTRUCTIONS TO CANDIDATES

1. Write your name, index number and class above.
2. Do not turn over this page until you are told to do so.
3. Follow all instructions carefully.
4. Answer all questions.
5. Use a dark blue or black ballpoint pen to write your answers and use a pencil for drawings, diagrams or graphs.
6. Do not use correction fluid/tape.
7. Do not use highlighter on any part of your answers.

Booklet	Maximum Marks	Marks Obtained
A	60	
B	40	
Total	100	

This booklet consists of 15 printed pages.

For questions 31 to 40, write your answers in this booklet.
The number of marks available is shown in brackets [] at the end of each question or part question.

(40 marks)

- 31 Mr Tan collected data on the average breathing rates of people from different age groups at rest.

People from different age group	Breathing rate (number of breaths per minute)
Adults	10 to 15
Children	18 to 30
Newborn Babies	30 to 60

Table 1

- (a) Based on the results shown in Table 1, state the relationship between the [1] breathing rate and the age of a person.

(Continues on next page)

SCORE	1
-------	---

An experiment was conducted to measure the volume of air that the lungs could hold.

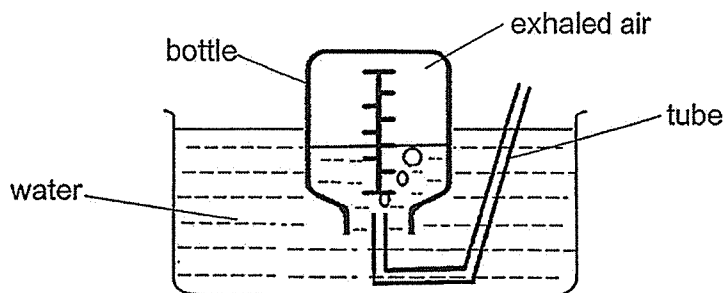

Mr Tan took a deep breath and exhaled as much air as possible into the tube as shown in the diagram above. The air will force out the water in the bottle. The volume of exhaled air in the bottle was then recorded. The experiment was repeated with his 5-year-old son.

	Volume of air exhaled (ℓ)
Mr Tan	6
5-year-old son	2.5

Table 2

- (b) Tick (✓) the variable(s) that should be kept the same to ensure a fair experiment. [1]

Variables	To be kept the same
Length of the tube used	<input type="checkbox"/>
Time taken by Mr Tan and his son to exhale the air into the tube	<input type="checkbox"/>
Volume of water in the bottle at the start of the experiment	<input type="checkbox"/>

- (c) Based on the results in Table 2, explain why Mr Tan's 5-year old son has a [2] higher breathing rate compared to Mr Tan.

SCORE	3
-------	---

- 32 John is allergic to peanuts and he cannot eat them. The diagram below shows an airway in his lungs before and after he ate peanuts.

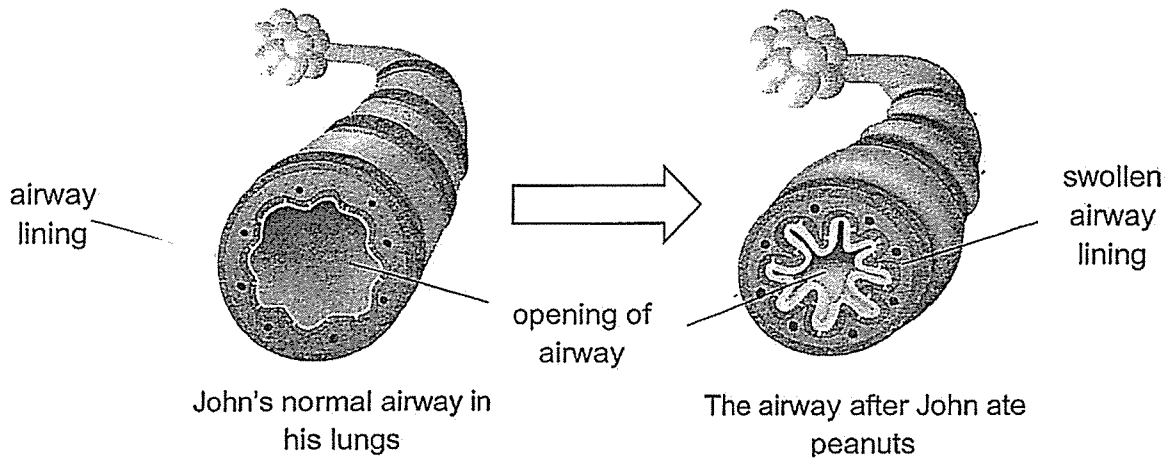

- (a) After eating peanuts, John found it difficult to breathe. Explain why. [1]

- (b) An oximeter is used to measure the amount of oxygen in blood. John placed an oximeter on his finger as shown in the diagram below.

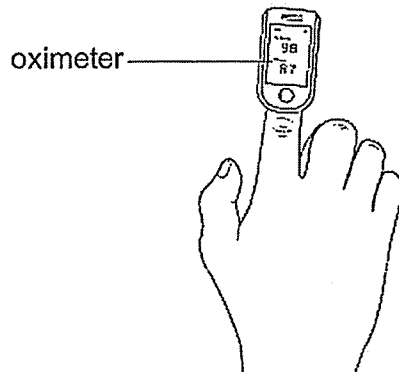

- Describe how John should plan his experiment using the oximeter on his finger [1] to find out if eating peanuts affects the amount of oxygen in his blood.

(Continues on next page)

SCORE	2
-------	---

The table shows the percentage of oxygen available in the surrounding as climbers climbed up the mountains.

Height above sea level (m)	Percentage of Oxygen (%)
0	20.9
914	18.6
1829	16.6
2743	14.8
3658	13.2
5182	11.0

- (c) As the climbers climbed higher, their heart rates increased. Based on the table, explain why the heart rate of the climbers increased as they went higher up the mountain. [2]

SCORE	2
-------	---

- 33 The bar graph shows the amount of digested food at different parts, A, B, C and D of the human digestive system.

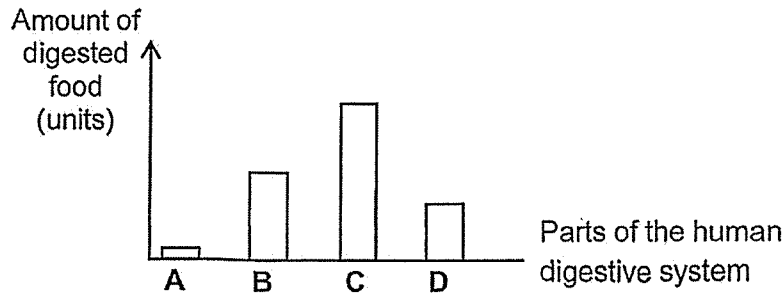

- (a) Which part of the digestive system, A, B, C or D, is most likely the small intestine? Explain why. [1]

The table below shows the time taken for food particles of different sizes to be fully digested in human digestive juices.

Food Size (mm)	Time Taken for Digestion (minutes)
1	10
2	15
3	20
4	25
5	30

- (b) Based on the information in the table, how does the size of food particle affect the time taken for it to be fully digested? [1]

- (c) Based on the information in the table, how does chewing our food more times affect the time taken for our digestion? Explain your answer. [2]

SCORE	4
-------	---

34 Fewer fruits have been produced by a fruit farm. The frequent use of pesticides had killed many bees and butterflies.

(a) Explain how the use of pesticide could have resulted in fewer fruits being harvested. [2]

The diagram below shows a vanilla orchid flower. The reproductive parts of the flower are hidden in the circled part of the flower.

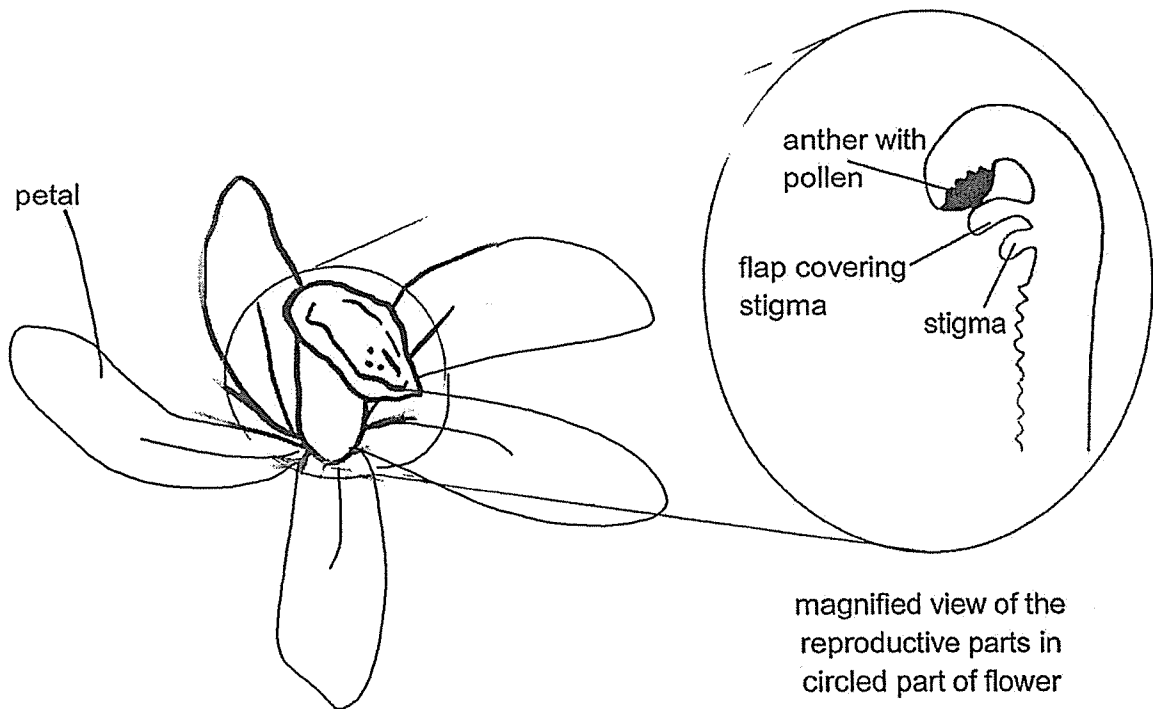

(b) The vanilla plant is unable to bear fruits when it is left on its own due to the special structure of the vanilla flower.

Based on the diagram above, explain why it is difficult for the flower to develop into a fruit. [2]

SCORE	4
-------	---

35 The diagram below shows how water is transported to different parts of a plant.

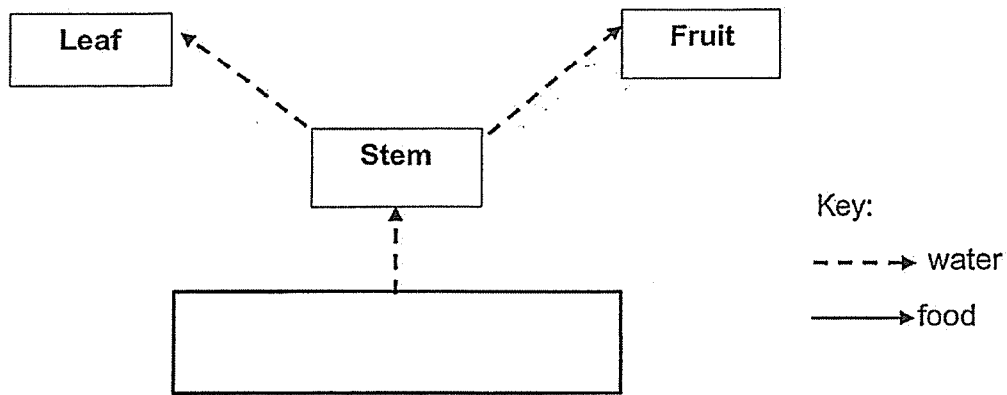

- (a) Fill in the box above with the correct plant part to show how water is transported in the plant. [1]
- (b) Draw arrows (→) in the diagram above to show the direction of how food is transported in the plant. [1]

To get bigger fruits, farmers sometimes cut off some smaller fruits.

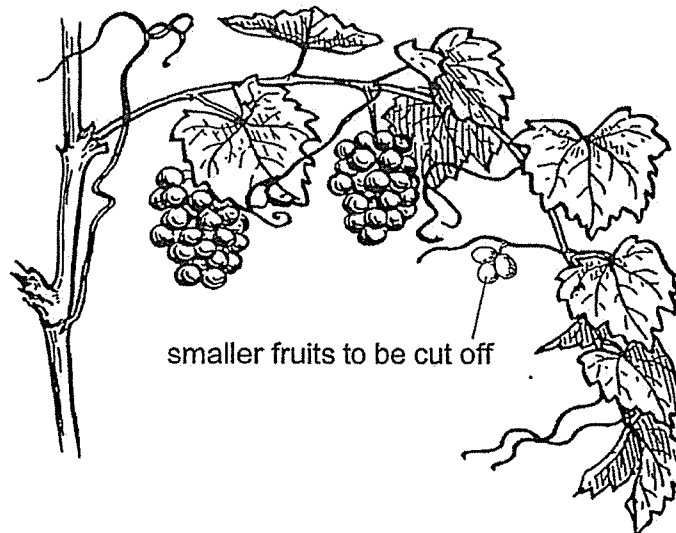

- (c) Explain why cutting away some smaller fruits helps the other fruits to grow bigger. [2]

SCORE	4
-------	---

- 36 Mandy hung two identical wet towels, P and Q, each weighing 100 g on a pole to dry. Towel P was hung unfolded while towel Q was folded in half as shown below.

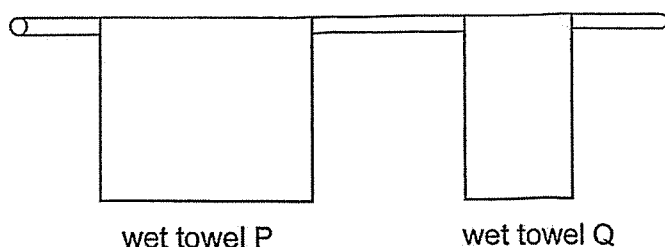

- (a) State the aim of Mandy's experiment. [1]

After two hours, Mandy measured the mass of towels P and Q and recorded the results in the graph below.

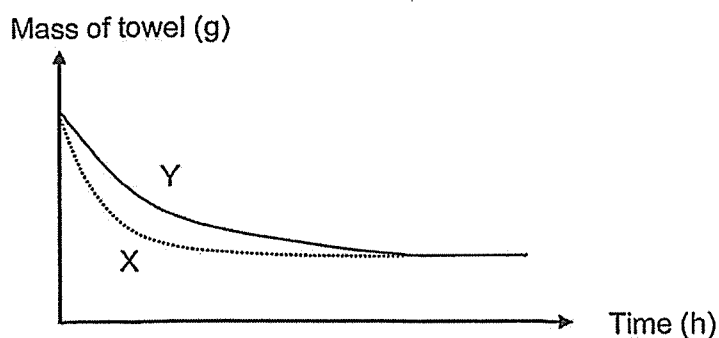

- (b) State which line, X or Y, in the above graph, shows the change in mass of towel P after an hour. Explain your answer. [2]

- (c) State another factor which can increase the rate of evaporation of the water in the towels. [1]

SCORE	
	4

37 (a) State what evaporation means.

[1]

Shahid was having lunch at an outdoor restaurant on a sunny day and he felt hot. He noticed there was a water mist system installed where tiny water droplets were released in the form of a mist as shown in the diagram. He felt cool sitting under the mist.

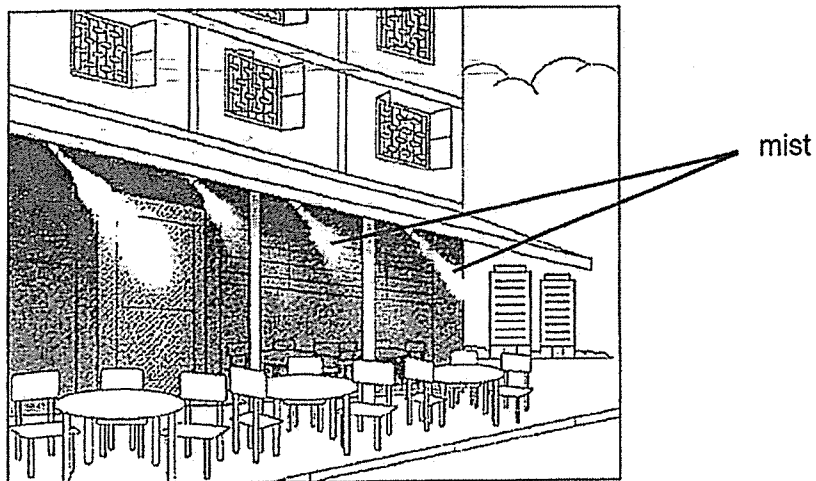

(b) Explain how such a system can lower the temperature of the surrounding air.

[1]

(Continues on next page)

SCORE	
-------	--

Fans were added to the water mist system as shown in the diagram.

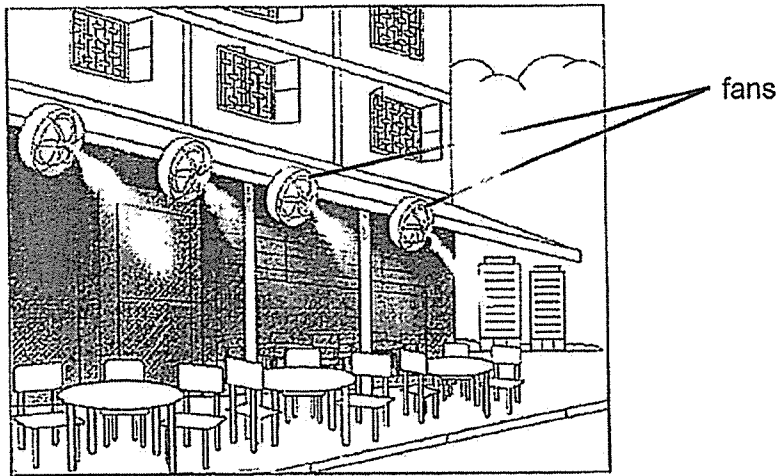

- (c) Explain how adding the fans to the mist system would help cool the surrounding air more effectively. [2]

SCORE	2
-------	---

- 38 Set-up A shows a 1-kg block of ice while set-up B shows 1-kg of ice cubes. Both set-ups were placed at the same location.

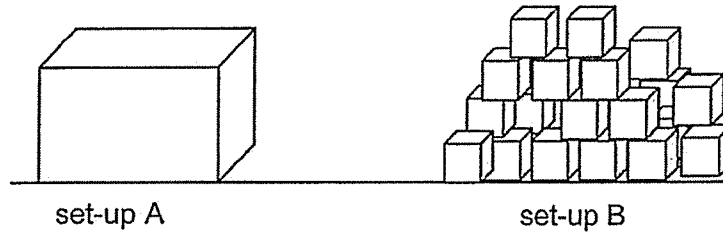

- (a) In which set-up, A or B, will the ice melt completely first? Explain your answer. [2]

The diagram below shows a container of ice cubes wrapped in some bubble wrap.

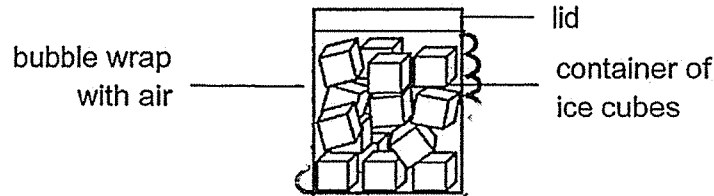

- (b) Explain how the bubble wrap prevents the ice cubes from melting quickly. [2]

SCORE	4
-------	---

- 39 The diagram below shows four bulbs, K, L, M and N, connected to two batteries. All the bulbs and batteries are in working condition.

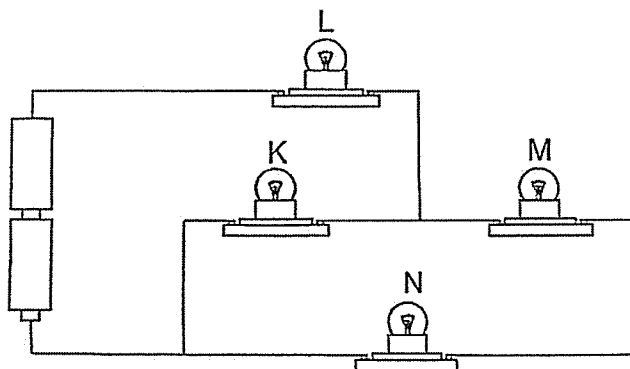

- (a) If bulb M fuses, which bulb(s) will remain lit? Explain your answer. [2]

- (b) Suggest one change to the circuit to make all the bulbs K, L, M and N brighter. [1]

- 40 The diagram below shows how a metal strip is used in a fire alarm system. The metal strip is placed on the ceiling of a canteen.

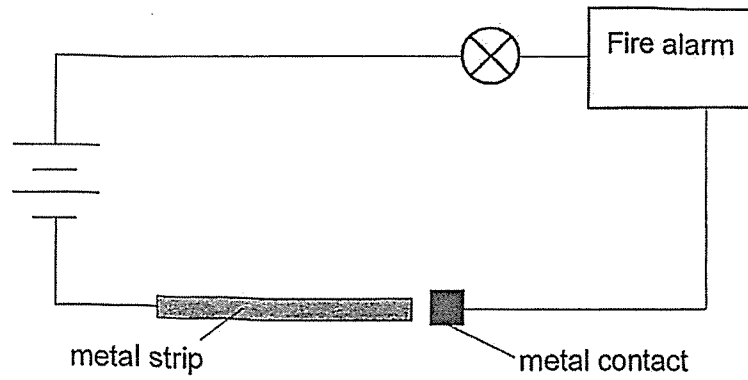

- (a) Other than being a good conductor of heat, state another property of the metal strip for the system to work. [1]

- (b) Explain how the above system works when there is a big fire in the canteen. [2]

(Continues on next page)

SCORE	3
-------	---

- (c) An engineer commented that the above fire alarm system will not work if the bulb fuses.

The diagram below shows part of the circuit of the system.

Use a pencil to complete the circuit so that if the bulb fuses, the fire alarm will still work. [2]

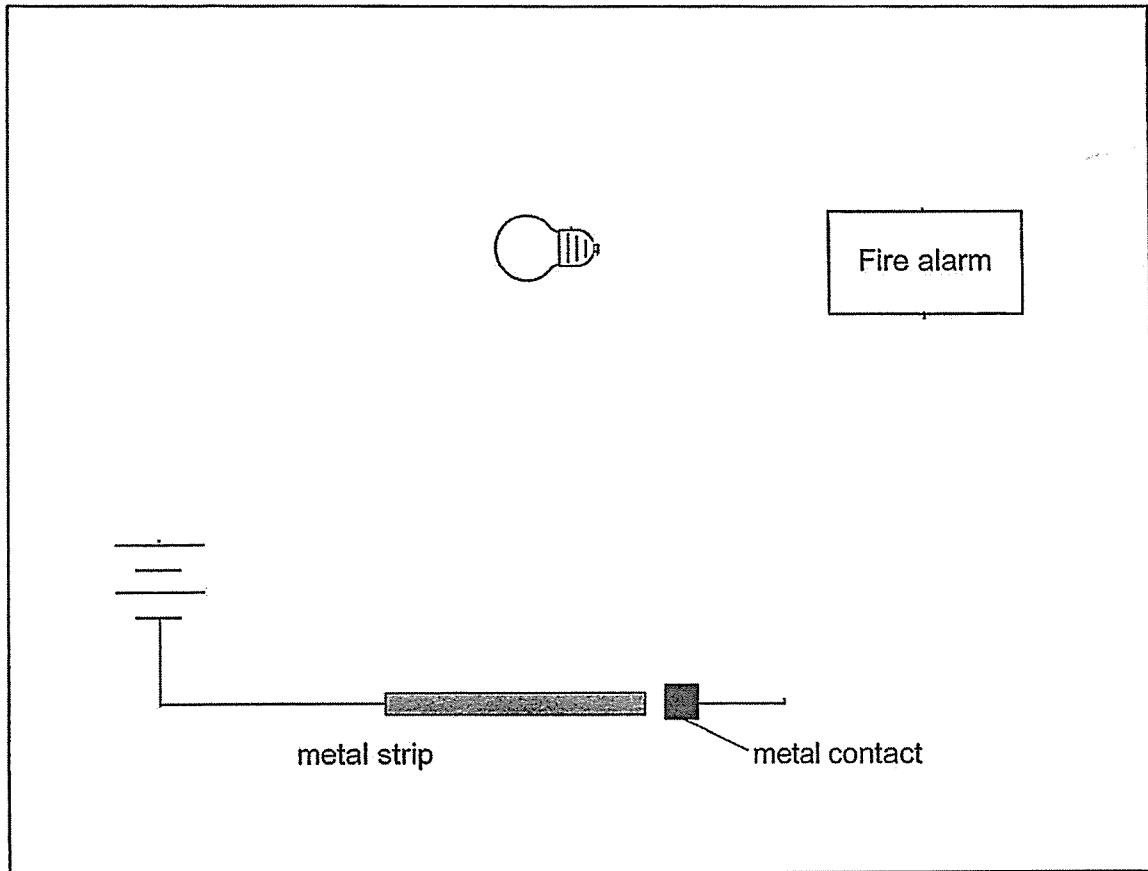

END OF PAPER

15

SCORE	2
-------	---

SCHOOL : ST HILDA'S PRIMARY SCHOOL
LEVEL : PRIMARY 5
SUBJECT : SCIENCE
TERM : 2025 END OF YEAR EXAMINATION

Q1	Q2	Q3	Q4	Q5	Q6	Q7	Q8	Q9	Q10
3	4	4	3	2	2	2	1	3	4
Q11	Q12	Q13	Q14	Q15	Q16	Q17	Q18	Q19	Q20
1	1	2	3	1	3	4	1	2	4
Q21	Q22	Q23	Q24	Q25	Q26	Q27	Q28	Q29	Q30
2	1	3	4	3	4	3	1	2	4

31a	As the age increases (decreases), the breathing rate decreases (increases).
31b	Length of the tube used Volume of water in the bottle at the start of the experiment
31c	Mr Tan's son exhaled less volume of air so his lungs hold less air. He is breathing faster take in more oxygen than Mr Tan for respiration.
32a	The opening of the airway is smaller. Less oxygen is able to pass through the airway when he breathes.
32b	He should measure the amount of oxygen in blood before and after he eats the peanuts.
32c	The lungs of the climbers take in less oxygen with each breath as they go higher up. The heart pumps blood faster to transport more oxygen (and digested food) in the blood to the muscles to release more energy and remove more carbon dioxide faster.
33a	C. C has the highest amount of digested food.
33b	As the size of the food particle increases (decreases), the time taken for it to be fully digested increases (increases).
33c	Chewing our food more times reduces the size of the food particles. It has

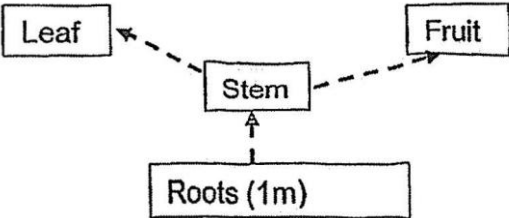
34a	The pesticides killed the bees and butterflies. There are no / fewer bees and butterflies to pollinate the flowers. No / less fertilisation can take place.
34b	Pollen from the anther cannot land onto the stigma as the flap covers the stigma. Hence, no pollination / fertilisation can occur.
35ab	
35c	There is fewer fruit that can store food. Hence more food will be transported to other fruits, hence the fruits grow bigger.
36a	To find out how the exposed surface area of the towel to its surrounding affects the rate of evaporation.
36b	Line X. The mass of the towel decreases faster than that of line Y. As towel P has a bigger exposed surface area to its surrounding, it has a higher rate of evaporation.
36c	(Presence of) wind / Higher outdoor temperature / low humidity / more heat
37a	Evaporation is a process where liquid (gains heat) and changes into gas at any temperature.
37b	The mist / water droplets gains heat from the surrounding air and evaporate
37c	The wind from the fan increases the rate of evaporation of the mist so the surrounding air loses heat faster (to the water droplets / mist) and surrounding temperature decreases.
38a	Set-up B. The ice cubes have a bigger exposed surface area in contact with its surrounding so they will gain heat faster from the surrounding and melt first.
38b	The air in the bubble wrap is a poor conductor of heat so the ice cubes gain heat slower from its surrounding and melt slower.
39a	Bulbs K and L. Electric current can flow through the closed circuit to lit up bulbs K and L.
39b	
40a	

40b

When there is a big fire, the temperature increases. The metal strip / metal contact gains heat and expands and will touch each other. Electric current can flow through the closed circuit to ring the alarm and (light up the bulb).

40c

